

Impact of Quantitative Analysis Techniques in Enhancing Time Management

Usman Ali Khan

Department of IS, King Abdulaziz University,
Jeddah, Saudi Arabia

Syed Faizan Haider

Department of IS, King Abdulaziz University,
Jeddah, Saudi Arabia

ABSTRACT

The identification of the most important tasks becomes virtually impossible for any project that comprises hundreds of the tasks with several dozens of its dependencies, those if missed (linked with meeting the deadline) may lead to the total, project impairment or failure. The CPM (critical path method) starting as hand-drawn diagrams, during 1950s was created as project management technique that keeps the Project on track till success by helping the identification of the tasks important in nature, evolving into automated software has now become an essential part of project planning scheduling, monitoring, along with controlling big or complex projects. For finding the critical path a simple algorithm has been designed in this paper. Use of the algorithm would prove to be enhancing the time management skills of the manager.

Keywords

Slack Time, PDM, Project Scheduling, PERT, Critical Path Network.

1. INTRODUCTION

PERT & CPM are two popular quantitative analysis techniques in the project management and these help in managing planning [1, 2] scheduling, monitoring, along with controlling big or complex projects. These techniques were established to manage project activities timely in a better way. [3,4]

The common steps to both PERT and CPM techniques are

- Defining the project with all its important tasks & activities.
- Developing the activities mutual relationship & deciding their precedence/s.
- Drawing a network that connects all the activities, with their time assignment.
- Computing the network's longest time path i.e. the Critical path.
- Using it to help planning, scheduling, monitoring along with project controlling.

In graphics mode, the most common technology is the critical path method-CPM, founded in 1956 for planning the network. This technology helps the decision maker to have their focus on the critical path, for the activities usually; along with this path are of the critical nature for a project. Batters and Thomas [5] in 1967 and 1969 proposed the concepts of total, safety, free & interference floats and the conclusion deduced from these concepts [6-9] was that the critical path was the one, with total float to be zero. While Elmaghra [10,12] in 1977 gave the node float concept, and he analyzed these floats.

2. IDENTIFICATION OF THE CRITICAL PATH

The Critical path's identification & analysis becomes significant and is traced on the basis of EST (Earlier Start Time) & LFT (Latest Finish time) throughout the tracing, because of its dependence on the success of the project.

3. ADVANTAGES OF THE CPM

A few of the benefits of the CPM are as below:

- Provides graphical view of the project.
- Gives dependencies visibility & their discovery.
- Helps plan, schedule and control the project, with further contingency planning..
- Identifying special attention requiring (critical) activities, hence giving the critical path
- It helps firstly assigning float and secondly flexibility to those float activities.
- It guides for the corrective action to taken for bringing back the project to track.

Not only the critical path is a very useful project planning tool but also bears some Cons and shortcomings.

4. DIS-ADVANTAGES OF THE CPM

Being CPM an optimal planning tool, it assumes all times availability of total resources for the project without considering resource dependencies.

Having chances for the misuse of float/ slack with non-critical activities those may become.

(Critical activities) if given less attention.

CPM based Projects often have the Time Track failure tendency.

In order to get rid of the shortcomings of the CPM, another method called CCM (Critical Chain method) was developed, that considers resource constraints to account during the network diagram development. The algorithm traces a graphical representation by taking into consideration many factors for initiating, maintaining and completing the tasks of a project in time. Hence the tasks, affecting the completion date of the project are considered as critical ones, while the path from the beginning till the completion of the project (in time, not the dates) is the critical path. The process facilitates the manager in: human resources (available) & the finances utilization to their optimum, further providing an opportunity for the timely completion of the project to view, review, modify & reschedule the tasks (avoiding delays).

5. TIME MANAGEMENT IN CPM

The role of analyzing the critical path is vital with respect to the time management of a project in an organization. It helps the project managers to figure out when and where are the resources required, the task to be rescheduled, refined or require acceleration, thereby avoiding the unnecessary delays in task completion [13].

Table 1: Set of activities and its abbreviation

A-Activity Identification
ES-Earliest Starting time
EF-Earliest Finish time
LS-Latest Starting time
LF- Latest Finish time
t-Activity Duration
X(A)=SET OF PREDECESSOR NODES TO NODES A
Y(A)=SET OF SUCCESSOR NODES TO NODES A

CPM

Calculating ES, EF, LS, LF & slack time

Early Start = calculate time at the start of the node

$$EF = ES + \text{duration}$$

Late Finish = calculate time at the ending of the node)

$$LS = LF - \text{duration}$$

$$\text{Slack Time} = \text{ESD} - \text{LSD}$$

Act	Dur	Pre	Post
A	2	-	C
B	3	-	D,F
C	5	A	E
D	9	B	E
E	5	C,D	G
F	5	B	G
G	2	E	

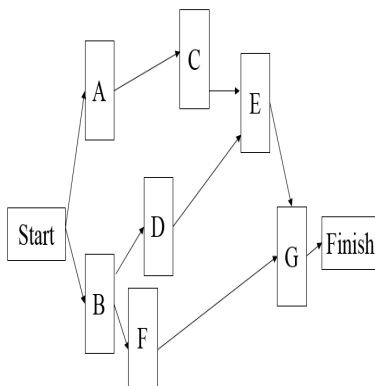

Figure 1: Precedence Network Diagram

If the slack time for all activities are zero in any network path is known as critical path.

Table 2: Calculation of ESD & , LS

<p>Calculating Early Start Date-ESD</p> <p>Early start date is the earliest possible time the activity could start.</p> <p>Activity A & B could start (at the earliest) at 0 because of no predecessor</p> <p>Activity C could start (at the earliest) at 2 as depend on completion of A</p> <p>Activity D & F could start (at the earliest) at 3 as depend on completion of B</p> <p>Activity E is depend on C & D activities, therefore E could start (at the earliest) at 12 (TAKING THE MAX VALUE) as depend on completion of C & D</p> <p>Activity F could start (at the earliest) at 3 as depend on completion of B</p> <p>Activity G could start (at the earliest) at 17 as depend on completion of E</p>
<p>Calculating LS (Latest Start Date)</p> <p>Late start Date is the latest possible time the activity could start.</p> <p>LS = MAX Duration-DURATION OF LAST ACTIVITY.</p> <p>Activity G latest START TIME) at 17 (crit path-2).</p> <p>Activity F latest START TIME) at 14 (crit path-5).</p> <p>Activity E latest START TIME) at 12 (17-5).</p> <p>Activity D latest START TIME) at 3 (12-9).</p> <p>Activity C latest START TIME) at 7 (12-5).</p> <p>Activity B latest START TIME DEPEND ON TWO ACTIVITIES D & F (WILL BE TAKEN THE MIN VALUE) at 0 (3-3).</p> <p>Activity A latest START TIME) at 2 (7-5).</p>

6. SLACK TIME CALCULATION

If the slack time for all activities are zero in any network path is known as critical path.

Table 3: Calculation of ES, LS, EF, LF and Slack time

EFT (Early Finish Time) Calculation	
Early Finish is the earliest possible time could finish the activity.	
Early Finish = Early Start + Activity Duration.	
Activity A could finish (at the earliest) at 2 (0 + 2)	
Activity B could finish (at the earliest) at 3 (0 + 3)	
Activity C could finish (at the earliest) at 7 (2 + 5)	
Activity D could finish (at the earliest) at 12 (3 + 9)	
Activity E could finish (at the earliest) at 17 (12 + 5)	
Activity F could finish (at the earliest) at 8 (3 + 5)	
Activity G could finish (at the earliest) at 19 (17 + 2)	
LFT (Latest Finish Time) Calculation	
Latest finish is the latest possible time the activity could finish without affecting the overall project time.	
Latest Finish Time=Latest Start Time+ Activity Duration	
Activity A could finish (at the latest) at 7 (5+2)	
Activity B could finish (at the latest) at 3 (0+3)	
Activity C could finish (at the latest) at 12 (7+5)	
Activity D could finish (at the latest) at 12 (3+9)	
Activity E could finish (at the latest) at 17 (12+5)	
Activity F could finish (at the latest) at 19 (14+5)	
Activity G could finish (at the latest) at 19 (17+2)	

Labeling the CPM

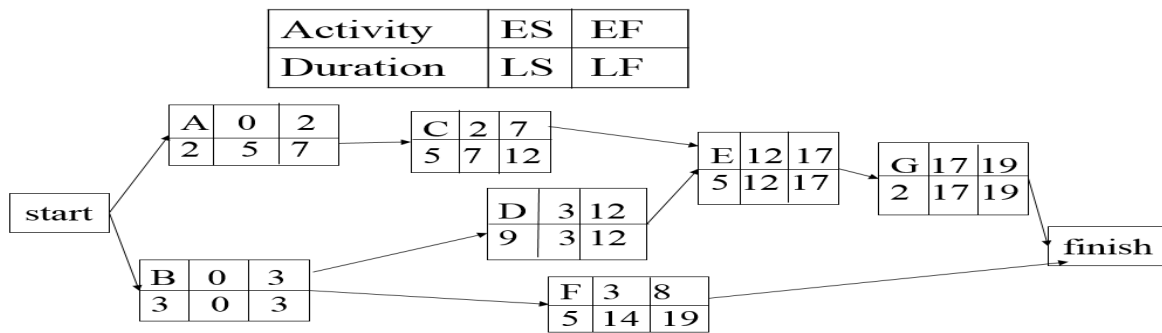

Figure 2: Labeling the Precedence Network Diagram

Table 4: Detail Calculation of CPM in Excel Sheet

ACTIVITY	OPTIMISTIC, a	MOST PROBABLE, m	PESSIMISTIC, b	EXPECTED TIME, $t = [(a+4m+B)/6]$	PREDECESSORS	EARLIEST START, ES	LATEST START, LS	EARLIEST FINISH, EF	LATEST FINISH LF	SLACK TIME	CRITICAL PATH
A	1	2	3	2	NONE	0	5	2	7	5	NO
B	2	3	4	3	NONE	0	0	3	3	0	YES
C	4	5	6	5	A	2	7	7	12	3	NO
D	8	9	10	9	B	3	3	12	12	0	YES
E	2	5	8	5	C, D	12	12	17	17	0	YES
F	4	5	6	5	B	3	14	8	19	11	NO
G	1	2	3	2	E	17	17	19	19	0	YES

Impact of Quantitative Analysis Techniques in Enhancing Time Management

Table 5: Slack Time Calculation

ACTIVITY	DURATION	PREDECESSORS	Sample Computations FOR earliest start and earliest finish activity time	EARLIEST START, ES	EARLIEST FINISH, EF	Sample Computations FOR latest start and latest finish activity time	LATEST START, LS	LATEST FINISH LF	SLACK TIME	CRITICAL PATH
A	2	NONE	$ES(A)=\text{Max}\{EF(j), j \text{ in } X(A)\}=EF(\text{start})=0$ and $EF(A)=ES(A)+A=0+2=2$	0	2	$LF(A)=\text{Min}\{LS(i), i \text{ in } S(A)\}=2$ and $LS(G)-tF=2-7=5$	5	7	5	NO
B	3	NONE	$ES(B)=\text{Max}\{EF(j), j \text{ in } X(B)\}=EF(\text{start})=0$ and $EF(B)=ES(B)+B=0+3=3$	0	3	$LF(B)=\text{Min}\{LS(i), i \text{ in } S(B)\}=3$ and $LS(F)-tF=14-3=11$	0	3	0	YES
C	5	A	$ES(C)=EF(A)=2$ AND $EF(C)=ES(C)+5=7$	2	7	$LF(E)=\text{Min}\{LS(i), i \text{ in } S(E)\}=17$ and $LS(G)-tF=17-5=12$	7	12	3	NO
D	9	B	$ES(D)=EF(B)=3$ AND $EF(D)=ES(D)+9=12$	3	12	$LF(D)=\text{Min}\{LS(i), i \text{ in } S(D)\}=12$ and $LS(D)-tF=12-9=3$	3	12	0	YES
E	5	C, D	$ES(E)=EF(C, D)=12$ AND $EF(E)=ES(E)+5=17$	12	17	$LF(E)=\text{Min}\{LS(i), i \text{ in } S(E)\}=17$ and $LS(G)-tF=17-5=12$	12	17	0	YES
F	5	B	$ES(F)=EF(B)=3$ AND $EF(F)=ES(F)+5=8$	3	8	$LF(F)=\text{Min}\{LS(i), i \text{ in } S(F)\}=19$ and $LS(G)-tF=19-5=14$	14	19	11	NO
G	2	E	$ES(G)=EF(E)=17$ AND $EF(G)=ES(G)+2=19$	17	19	$LF(G)=\text{Min}\{LS(i), i \text{ in } S(G)\}=19$ and $LS(G)-tF=19-2=17$	17	19	0	YES

7. CONCLUSION & FUTURE WORK

The role of CPM is vital with respect to the timely schedule management of a project. Controlling the key elements is not that difficult but scheduling of critical path may get tedious when there are several activities. The designed algorithm resolves the issue of finding the critical path in network diagram. The process facilitates the manager in human resources (available) & the finances utilization to their optimum, further providing an opportunity for the timely completion of the project to view, review, modify & reschedule the tasks (avoiding delays and failure). The future improvement in the algorithm for more feasibility, flexibility, acknowledgment of the existence of iterations & study network planning have been suggested. Point of development, the theorem and in this paper have important significance.

REFERENCES

[1] S. E. Elmaghraby, "On Criticality and Sentivity in Activity Networks," European Journal of Operational Research, vol.127, pp. 220-238, 2000.

[2] J. E. Kelley and M. R. Walker, "Critical Path Planning and Scheduling," In: Proceedings of the Eastern Joint Computational Conference, vol. 16, pp. 160-172, 1959.

[3] C. L. Liu and H. Y. Chen, "Critical Path for an Interval Project Network," Journal of Management Sciences in China, vol.9, no. 1, pp. 27-32, 2006.

[4] S. H. An, P. R. Jie and G. G. He, "Comprehensive Importance Measurement for Nodes within a Node-Weighted Network," Journal of Management Sciences in China, vol. 9, no. 6, pp. 37-42, 2006.

[5] S. E. Elmaghraby, Activity Networks: Project Planning and Control by Network Models, New York: John Wiley & Sons Inc., 1977.

[7] S. E. Elmaghraby, "Activity Nets: a Guided Tour through Some Recent Developments," European Journal of Operational Research, vol. 82, pp. 383-408, 1995.

[8] X. M. Li and J. X. Qi, "Study on Time-Scaled Network Diagram Based on the Analysis of Activity Floats," Operations Research and Management Science, vol. 15, no. 6, pp. 28-33, 2006.

[9] X. M. Li, J. X. Qi and Z. X. Su, "The Research on Resource Leveling Based on the Analysis of Activity Floats," Chinese Journal of Management Science, vol. 15, no. 1, pp. 47-54, 2007.

[10] D. J. Michael, J Kamburowski and M. Stallman, "On Minimum Dummy Arc Problem," Operations Research, vol. 27, no. 2, pp. 153-168, 1993.

[11] E. L. Demeulemeester and W. S. Herrlelen, Project Scheduling, Boston: Kluwer Academic Publishers, 2002.

[12] S. E. Elmaghraby and Kamburowski, "On Project Representation and Activity Floats," Arabian Journal of Science and Engineering, vol. 15, pp. 627-637, 1990.

[13] Quantitative Analysis For Management-7 edition by Barry Render and Ralph M. Stair, LR: Prentice Hall International, Inc