

Design and Drafting of a Gear Box for Plastic Extrusion Process

Nikhil Gupta
Mechanical Engineering
Department, IIMT College of
Engineering,
Greater Noida (U.P.) India

Krishna Kumar Karothiya
Mechanical Engineering
Department, IIMT College of
Engineering,
Greater Noida (U.P.) India

Sumer Singh
Mechanical Engineering
Department, IIMT College of
Engineering,
Greater Noida (U.P.) India

ABSTRACT

In this paper we have analyzed the different types of gearbox in use of an extrusion process. The type of gears, bearing and their arrangement used as according to power transmitted, working speed range and type of lubrication used. In the light of information gathered and considering our problem, we decided to design a two stage reduction gear box using single helical gears. Now, as according to the power to be transmitted (20 K.W) velocity ratio per stage decided (4- For the first stage, 5- for the second stage) we designed the helical gears taking helix angle as 18° and pressure angle as 20° . Using the various loads we calculated the diameters of different shafts now the bearings were attached to the shaft on the basis of their diameter, reactions were calculated on the bearings and then according to these reactions bearing were selected. The modeling and design of the reducer gear box has been done with the help of ProE and C++ Language respectively.

Keywords: Plastic extrusion, Helical gears box, C++ Language, Analytical analysis.

1. INTRODUCTION

The gears are manufactured from the different type of material according to the application; the gears are made of non ferrous, ferrous & no metallic material. However steel gears are widely used because the steel may be hardened to the various levels of hardness & strength. Gear steels may be divided into two general classes – the plain carbon and the alloy steels. Alloy steels are used to some extent in the industrial field, but heat treated plain carbon steels are far more common. The use of untreated alloy steels for gears is seldom, if ever, justified, and then, only when heat-treating facilities are lacking. The points to be considered in determining whether to use heat-treated plain carbon steels or heat-treated alloy steels are: Does the service condition or design require the superior characteristics of the alloy steels or, if alloy steels are not required, will the advantages to be derived offset the additional obtain the best of their qualities for the service intended, are satisfactory and quite economical.

2. CALCULATION FOR GEARS

Given:-

Inlet r.p.m to the shaft, n_1 = 1500
Outlet r.p.m. to out put shaft n_2 = 75
Velocity ratio = 20
Power to be transmitted = 20 K.W.
Because V.R. is more than 15 i.e. 20, it will be economical, if we select the two stage gear box.

2.1 Selection of Number of Teeth for Pinion and Gear

2.1.1 For First Stage

Let V.R. for first stage i_1 = 4
V.R. for second stage i_2 = 5
Total Nos. of teeth on pinion = N
 Min^m nos. of teeth on pinion = N_p
 Min^n nos. of teeth on wheel = N_w

$$N = 150, \frac{N_w}{N_p} = V.R. = 4$$

$$N_p + N_w = 150$$

$$i.e. N_p = 30 \quad N_w = 120$$

2.2 Check for Minimum Number Of Teeth On Pinion To Avoid Interference

Let, Angle of pressure $\alpha = 20^\circ$ (Assumed)
Addendum "a" is equal to module (Assumed)
Using these values in the following relation to avoid interference.

$$\frac{N_p^2}{N_w} + 2N_p = 4k \left[\frac{10 + \frac{k}{N_w}}{\sin^2 \alpha} \right];$$

$$N_p^2 + 2N_p = 4 \left[\frac{1 + \frac{1}{120}}{\sin^2 20} \right]$$

$$N_p^2 + 240N_p - 4137.53 = 0$$

$$N_p = \frac{-240 + \sqrt{240^2 - 4 \times 1 \times 4137}}{2 \times 1} = 16$$

The calculated No of teeth on pinion is 30 i.e. our selection of teeth are safe.

3. DESIGN OF GEAR

Let us consider the following data

Teeth of pinion	(N_p)	=	30
Teeth of wheel	(N_w)	=	120
Power transmitted	(P)	=	20 K.W.
Speed of input shaft	(n_1)	=	1500 r.p.m
Speed of intermediate shaft	(n_2)	=	375 r.p.m
Speed of output shaft	(n_3)	=	75 r.p.m
Helix angle	(β)	=	18 degree

K is Design load factor = 1.5 = $K_c \times k_d$

Selected the medium carbon alloy steel normalized & tempered for which permissible surface stress=2.6 B.H.N.

B.H.N.	=	360 (assumed)
Pressure angle (α)	=	20 degree
Factor of safety	=	1.6

3.1 Centre Distance

We know the exact centre distance "A" is given by the following formula for Helical gear.

$$A = 290 \times 10^4 \left[\frac{KP(i+1)^3}{\pi \times n_p i \psi_A \sigma_{sur}^2} \right]^{1/3}$$

$$= 0.138 \text{ m}$$

Module

$$m = \frac{2A}{(i+1)N_p} = \frac{2 \times 138}{(4+1) \times 30} = 1.84$$

Face Width

$$\text{Width } b = \psi_a \times A = 0.6 \times 150 = 90 \text{ mm.}$$

Pitch Circle Diameter D_p & D_w

$$D_p = \frac{2A}{(i+1)} = \frac{2 \times 150}{(4+1)} = 60 \text{ mm}$$

Final Dimension for first stage

V.R. (i)	=	4
Dia of pinion P.C.D. D_p	=	60 mm.
Dia of gear or wheel D_w	=	240 mm.
Face width of the gears b	=	90 mm.
Module m	=	2.

Center distance between axis of the pinion and wheel $A = 150$ mm

3.2 Second Stage

Teeth on pinion gear for intermediate shaft and output shaft.

Let total Nos. of teeth $N = N_p + N_w = 198$ (From table 11.5)

V.R. (i)	=	4
Nos. of teeth of pinion N_p	=	33
Nos. of teeth of gear N_w	=	165
Input r.p.m (Intermediate R.P.M.) n_1	=	375
Output R.P.M n_2	=	75

$$A = 290 \times 10^4 \left[\frac{1.4 \times 25(5+1)^3}{\pi \times 375 \times 5 \times 0.6 \times (569 \times 10^6)^2} \right] = 0.283 \text{ m}$$

Module

$$m = \frac{2A}{(i+1)N_p} = \frac{2 \times 238}{(5+1)33} = 2.4$$

Center Distance

$$A = \frac{(i+1)N_p \times m}{2} = \frac{6 \times 33 \times 2.5}{2} = 247.5 \text{ mm}$$

Face Width

$$b = \psi_A \times A = 0.6 \times 247.5 = 148.5 \text{ mm}$$

Pitch Circle Diameter D_p & D_w

$$D_p = \frac{2A}{(i+1)} = \frac{2 \times 247.5}{6} = 82.5 \text{ mm}$$

$$D_w = \frac{2Ai}{(i+1)} = \frac{2 \times 247.5 \times 5}{6} = 412.5 \text{ mm}$$

4. FINAL DIMENSION FOR INTERMEDIATE PINION & OUTPUT GEAR

Center distance A	= 247.5 mm
Module m	= 2.5 mm
Face width b	= 148.5 mm
Pitch circle dia D_p	= 82.5 mm
Pitch circle D_w	= 412.5 mm

4.1 Check for Bending & Surface Strength

4.1.1 Bending Strength for First Pinion

We know permissible bending stress.

$$\sigma_b = \frac{0.7\sigma_u}{K_e \times f} = 421 \text{ MPa}$$

$$\sigma_{\max} = \frac{6000 \times 20 \times 1.4 \times 10^9}{\cos 20^\circ \times \pi^2 \times 1.9^3 \times 1500 \times 152 \times 31.58} \times \frac{1}{0.194} \times \frac{1}{1.35}$$

$$= 157.5 \times 10^6 \text{ Pa}$$

Because our working bending stress $\sigma_{\max} = 158 \text{ MPa}$ in pinion teeth is very less than permissible bending stress $\sigma_b = 421 \text{ MPa}$ so our design against bending strength is safe.

4.1.2 Bending Strength for First Gear

$$\sigma_{\max} = \frac{6000 \times 20 \times 1.4 \times 10^9}{\cos 20^\circ \times \pi^2 \times 1.9^3 \times 375 \times 139.5 \times 126.32} \times \frac{1}{0.144}$$

$$= 136.20 \times 10^6 \text{ Pa} = 136 \text{ MPa}$$

Because our working bending stress ($\sigma_{\max} = 136 \text{ MPa}$) in gear teeth is very less than permissible bending ($\sigma_b = 421 \text{ MPa}$). Therefore our design against bending for second or intermediate gear is safe.

4.1.3 Bending Strength for Intermediate Pinion

$$\sigma_{\max} = \frac{6000 \times 20 \times 1.4 \times 10^9}{\cos 20^\circ \times \pi^2 \times 2.38 \times 375 \times 383.6 \times 346.0 \times 1.35 \times 0.120}$$

$$= 94.2 \times 10^6 \text{ Pa} = 94 \text{ MPa}$$

The Maximum permissible bending stress = 421 MPa

$94 < 421$, Therefore the design of pinion against bending is safe.

4.1.4 Bending Strength for Output Gear

$$\Sigma_{\max} = \frac{6000 \times 20 \times 1.4 \times 10^9}{0.94 \times \pi^2 \times 2.383 \times 75 \times 191.81 \times 173.32 \times 1.35 \times 0.147}$$

$$= 17.0 \times 10^6 \text{ Pa} = 17 \text{ MPa}$$

$421 \text{ MPa} > 17 \text{ MPa}$, Hence our design against bending strength is safe.

4.2 Check for Surface Strength

4.2.1 for First Pinion

$$\sigma_{\max} = 4.82 \times 10^8 \text{ Pa} = 482 \text{ MPa}$$

4.2.2 For The First Gear

$$\sigma_{\max} = 9.64 \times 10^8 \text{ Pa} = 964 \text{ MPa}$$

The maximum working surface stress is more than permissible working stress, so our design for gear is not safe so we increase the hardness for gear.

Now the increased value of hardness for gear = 500 B.H.N.

$$\sigma_{\max} = 2.6 \times 500 = 1300 \text{ MPa}$$

Now the working surface stress is 964 MPa is less than permissible surface stress 1300 MPa, so our design is safe against surface failure.

4.2.3 For the Intermediate or Second Pinion

$$\sigma_{\max} = 1196 \text{ MPa}$$

$1196 \text{ MPa} > 910 \text{ MPa}$ so our design is not safe than we have to increase the surface hardness. Now we will increase the BHN upto 600.

Maximum permissible surface stress = $2.6 \times 600 = 1560 \text{ MPa}$

For the 600 B.H.N. the maximum permissible surface stress is 1560 MPa which is greater than maximum working surface stress 1196 MPa, so our design against surface failure is safe.

4.2.4 Output Gear

$$\sigma_{\max} = 2.6 \times 600 \text{ MPa} = 1560 \text{ MPa}$$

$$\sigma_{\max} = 1200.0 \text{ MPa}$$

$\sigma_{\max} \text{ working} < \sigma_{\max} \text{ permissible}$, therefore our design is safe

5. RESULT AND DISCUSSION

5.1 Final Dimensions for Gear Box

5.1.1 Gear Design

Stage 1

Input shaft rpm	= 1500 rpm
Output shaft rpm	= 375 rpm
Module	= 2.00
Gear Ratio	= 4.00
D_p	= 60.00 mm
D_w	= 240.00 mm
Width	= 90.00 mm
Center Distance	= 150.00 mm

Power Transmitted = 20.00 KW

Stage 2

Input shaft rpm = 375 rpm
Output shaft rpm = 75 rpm
Module = 2.500
Gear Ratio = 5.00
Dp = 82.50 mm
Dw = 412.50 mm
Width = 148.50 mm
Center Distance = 247.50 mm
Power Transmitted = 20.00 KW

5.1.2 Shaft Design

Input Shaft Dia = 40 mm
Intermediate Shaft Dia = 65 mm
Output Shaft Dia = 95 mm
Material of shafts : Low Carbon Steel

5.1.3 Design of Reduction Gearbox Casing

Thickness of the casing wall = 12.50 mm
Thickness of cover wall = 10.50 mm
Minimum clearance b/w gear & inner wall of the cover = 13.00 mm
Thickness of top flange of casing = 18.75 mm
Thickness of the rib of the body = 12.50 mm
Diameter of the foundation bolt = 25.00 mm
Distance b/w flange bolts = 175.00 mm
Thickness of the cover taking = 16.00 mm
Thickness of the cover rib = 9.00 mm
Diameter of the bolts near bearing = 19.05 mm
Diameter of the flange bolts = 16.00 mm
Thickness of the foundation = 31.00 mm
Width of the top flange of casing = 19.00 mm
Width of the foundation flange = 65.00 mm
Length of the foundation flange = 1589.00 mm
Number of bolts for foundation = 8.00 mm

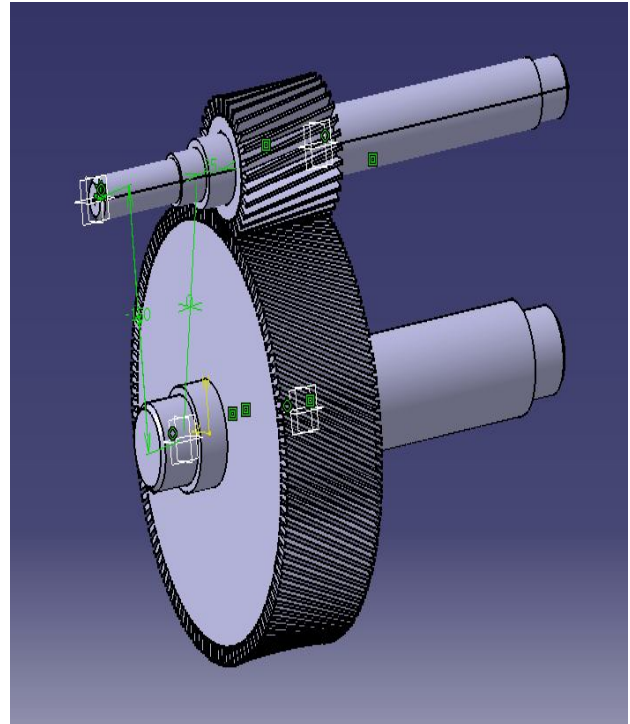

Figure.1 Drafting of Gear box

6. CONCLUSION

In this work we have worked on designing software ProE . The benefit of this software is that to develop an almost identical model of the product. There are various designing software available such as the pro e, inventor 3-d, catia v5, etc. This can develop the design more easily with high quality. We have also used c++ language to create a computer aided design of the reduction gear box. In which the user inputs the values and the program calculates all the necessary dimensions of the design parameters.

We designed a gear box as per the requirements of the extrusion machine. The output torque required was quite high in our case which has been achieved. The computer aided design of the reduction gear box for plastic extrusion machine has been achieved.

REFERENCES

1. E. Shigley “Mechanical engineering design” Tata McGraw hill Publication ,1985
2. V. B. Bhandhari, “Machine Elements” Tata McGraw hill Publication, 2008
3. K. Lingaiah “Machine Design Data Hand Book, Vol II , Suma Publishers, Bangalore, 1984.
4. G. M. Maitra “Hand book of gear Design”, Tata McGraw Hill Publication, 2005.
5. Yashavant Kanetkar “Let Us C” BPB publication 2006.